

## RNM2D\_0 Fast Stray Losses Hazard Evaluation on Transformer Tank Wall & Cover due to Zero Sequence

Xose M. LOPEZ-FERNANDEZ, Casimiro ALVAREZ-MARIÑO and Patricia PENABAD-DURAN

Department of Electrical Engineering, University of Vigo  
Campus Lagoas-Marcosende, E 36310 Vigo, Spain  
Phone: (+34) 813478, fax: (+34) 814014, e-mail: xmlopez@uvigo.es

Janusz TUROWSKI

Retired of Institute of Electrical Machines and Transformers  
Technical University of Lodz, Lodz, Poland

*Abstract* — In three-phase three limb core-form transformers under unbalanced conditions a component of the zero-sequence flux closes its path over the tank wall and cover. Classical solutions to overcome this problem are to consider a delta winding or to add a tertiary delta connected winding, however this paper means to evaluate the real impact of the zero-sequence flux, arising in unbalanced operating conditions, which is scarcely discussed in the literature. This paper presents a rapid and easy-to-use tool RNM2D\_0, based on the Reluctance Network Method to calculate magnetic magnitudes and evaluate the stray losses hazard effects due zero-sequence flux in transformers.

*Keywords* — Leakage flux, Zero-sequence flux, Reluctance-Network Method, Stray losses hazard, Three-phase, Three-limb transformer, Core type, Unbalanced faults.

### I. INTRODUCTION

Zero-sequence flux appears in a transformer without neutral conductor when in the core emerge harmonics of 3rd order, or at asymmetric load in which zero point is loaded. Extreme case of such asymmetric load is single-phase load or at single-phase short-circuit. At the same time certain faults may remain undetected by the standard protection, subjecting thus the transformer to prolonged operation with significant zero-sequence flux.

In the vast majority of three phase transformers core form construction is used. A small or medium rated transformer is usually of three-limb core-type. The primary and secondary windings of one phase are bounded around one core leg. Under balanced conditions, the currents in three phases are equal in magnitude, with shift angles of  $120^\circ$  where the resultant zero-sequence flux is null. However, if some unbalance occurs in the terminal voltage the three phase fluxes will not be cancelled and it has to return through a path out of the transformer magnetic core. In the case of a three phase transformer of three-limb core-type, the zero-sequence flux jumps from the top yoke, passes through a huge air or oil gap, closes by cover and the tank wall and returns to the bottom yoke (and vice versa). The classical solution to remove the presence of zero-sequence flux is to assemble a triangle (delta-connected) winding on the transformer. The triangle winding acts as a magnetic screen which does not transmit almost any equiphase flux inside such closed winding. It means that with this winding almost none of equiphase fluxes are coupled.

One of the dangerous consequences of the presence of zero-sequence flux is that the core, cover and tank may be heated to an unacceptable temperature due to additional stray losses.

Although the performance of transformers under unbalanced conditions are well know, and the classical adopted solution to consider a delta winding or add a tertiary delta winding is assumed, the real impact of the zero-sequence flux, arising in unbalanced operating conditions, is scarcely discussed and relevant information is difficult to find [1]. Therefore, in this paper, a fast tool called RNM2D\_0, based on the Reluctance Network Method, is proposed to evaluate the losses generated due to presence of zero-sequence flux in a three-phase and three limb core type transformers.

## II. BASIS OF RELUCTANCE NETWORK METHOD (RNM)

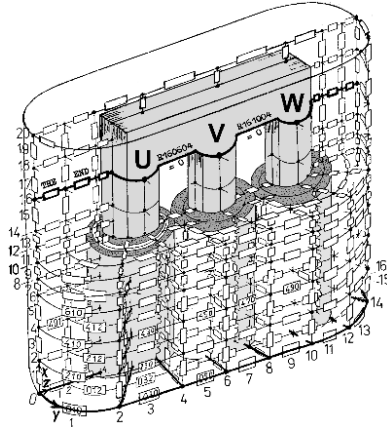

Figure. 1. 3-D Reluctance Network Model of a three-phase power transformer (a quarter of symmetric transformer) [3].

The equivalent Reluctance Network Method (RNM) is one of the simplest and fastest methods of modelling and computation [2]. The Three-Dimensional Reluctance Network Model (RNM-3D) was presented to compute the leakage magnetic field in three phase transformers, as can be seen in Fig. 1, by Professor J. Turowski in 1969 [3],[4]. Such modelling method is extremely competitive in market time compared with the nowadays popular Finite Element Method [5].

Theory and method of modelling and calculation of losses due to the electromagnetic field are based on Maxwell's equations and Poynting's vector theory. Full solution of Maxwell's equations with non-linear magnetic permeability  $\mu$  (H) and non-sinusoidal excitation is too complicated to be used in regular engineering computation. However, the RNM method is one of the oldest methods of modelling and solving magnetic circuits in electrical machines which offers an easier implementation. Since it is based on Ohm's Law for magnetic circuits (1), magnetic Kirchhoff's Laws for nodes (2) and for branches (3) [6].

$$MMF_i = \mathfrak{R}_i \Phi_i \quad (1)$$

$$\sum_{i=1}^n \Phi_i = 0 \quad (2)$$

$$\sum_{k=1}^m MMF_k = 0 \quad (3)$$

Where  $i$  are the branches and  $k$  the nodes of the equivalent network. The basic reluctances, for dielectric regions, are calculated using (4), where  $i$  represents the coordinates of the  $i$ -th element of the network and  $S_i$  is the cross section of the mesh element.

$$\mathfrak{R}_i = l_i / (\mu_0 S_i) \quad (4)$$

$$\mathfrak{R}_i = (\mathfrak{R}_{re} + j \cdot \mathfrak{R}_{im}) \cdot (l/a) \quad (5)$$

Where,  $\mathfrak{R}_{re} = a_1 \sqrt{(\omega\sigma / \mu_s)}$  and  $\mathfrak{R}_{im} = a_2 \sqrt{(\omega\sigma / \mu_s)}$ .

Solid metal structural elements (tank wall, cover, beams, etc.) need to be modelled by complex reluctances due to reaction eddy currents, non linear permeability and skin effect. These reluctances are calculated by means of (5), where  $\mu_s$  is the surface magnetic permeability,  $\omega$  is pulsation,  $\sigma$  electric conductivity and  $a_1$  and  $a_2$  are linearization [6] coefficients for solid steel. These complex nonlinear dependencies are hidden in the Source-Code, and invisible to the normal user of RNM-3D program. It is simple only for user.

The magnetomotive forces of the windings are calculated applying equation (6), assuming that entire ampere-turns at high voltage (HV) or low voltage (LV) windings are concentrated in the appropriate air-gap.

$$MMF = (\sqrt{2} I_{HV} N_{HV}) / 2 = \sqrt{2} I_{LV} N_{LV} \quad (6)$$

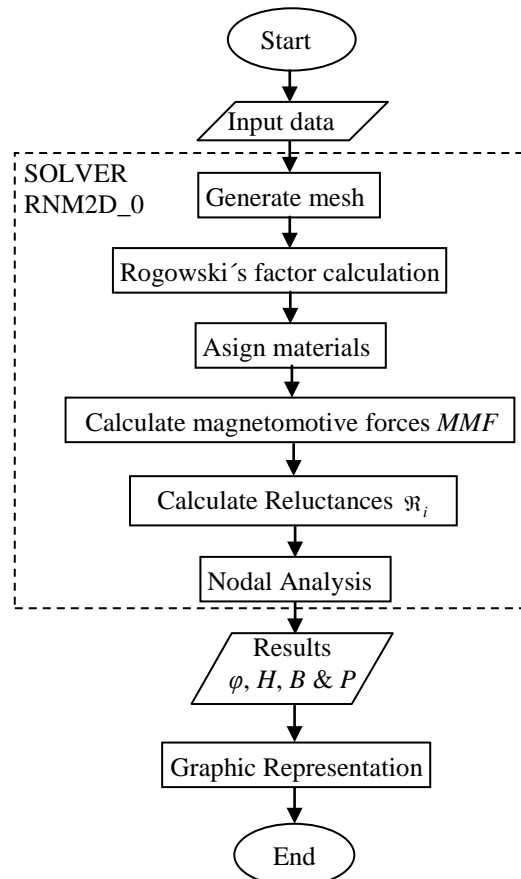

Figure 2. Flowchart corresponding to the RNM2D\_0 program.

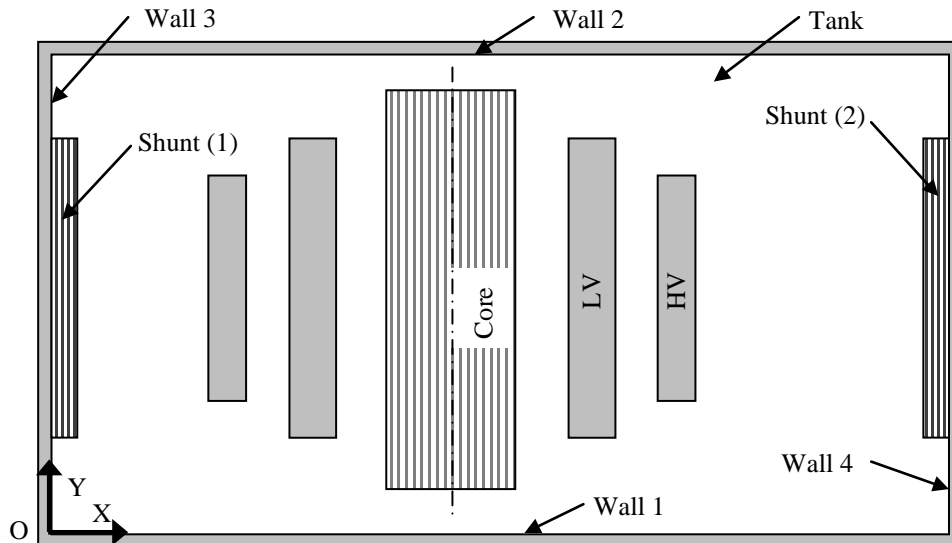

Figure 3. Representative transformer geometry.

### III. TRANSFORMER MODEL APPLYING RNM2D\_0

The flowchart in Fig. 2 shows the basic steps corresponding to the RNM2D\_0 program. The program starts by reading the input data from a file, continues by running the RNM2D\_0 solver and finally plots the obtained results over the tank wall and shunts. The solver starts with the physical description, firstly calculates the representative parameters of the geometry from the input data and generates the mesh, then calculates the Rogowski's factor and assigns material properties. The next step must be computing the electromotive force  $MMF$  and the reluctances, applying finally a nodal analysis to compute the results. In the following sections the main steps of the solver are explained in detail.

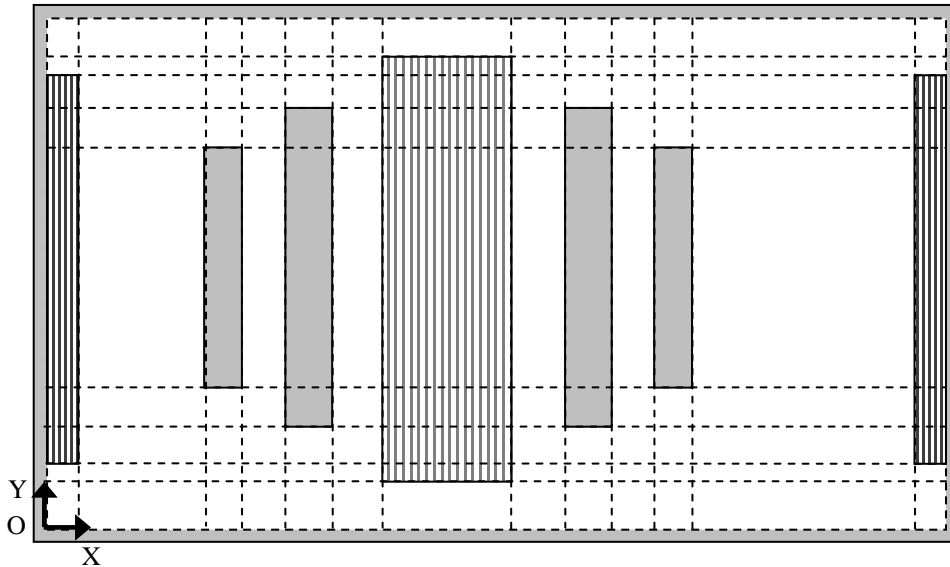

Figure 4. Coarse mesh description.

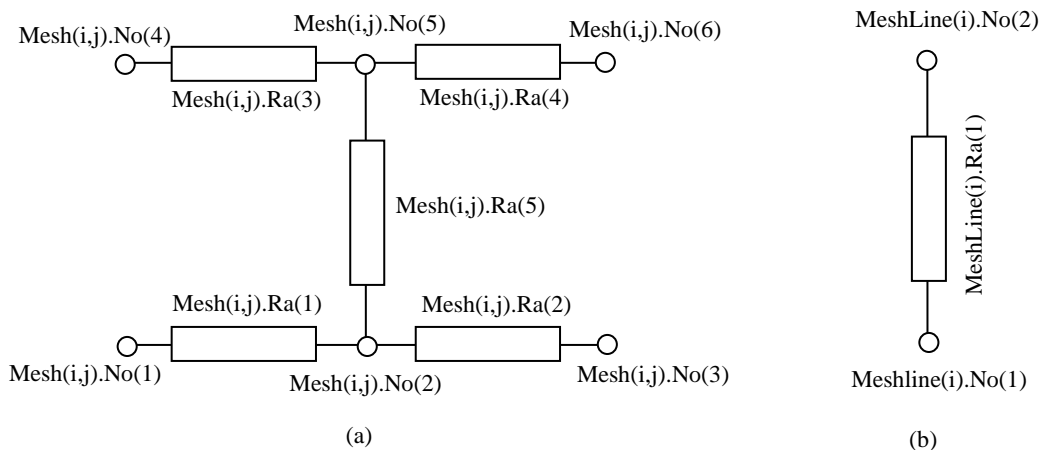

Figure 5. Fine mesh description, (a) inside the transformer, (b) in the tank.

## MESH GENERATION

In Fig. 3 the representative transformer geometry including tank walls, shunts, core and high voltage (HV) and low voltage (LV) windings is shown. The representative transformer geometry is discretized in a mesh, which defines the Reluctance Network modeling the transformer. To build the Reluctance Network, the solver generates a coarse mesh, and afterwards a fine mesh is built from the coarse mesh as seen in Fig. 5. The tank, core, shunts and windings geometry set the limits of the coarse mesh, as seen in Fig. 4.

## NODAL ANALYSIS

Once the Reluctance Network is calculated, the nodal analysis is applied by using the Chua nodal analysis method. The Chua method is based on the creation of a nodal system of equations from a structure of branches joint to each other by means of nodes.

Having obtained the system of equations solution from nodal analysis, values from magnetic field magnitudes are calculated for each reluctance; this is  $\varphi$  the magnetic flux in Weber,  $H$  the magnetic field intensity in A/m,  $B$  the magnetic induction in Tesla as well as power losses distribution  $P$  in  $W/m^2$ .

Figure 6. Magnetic induction  $B$  in Tesla over tank Wall 3 without shunts.

Figure 7. Power losses due to zero-sequence flux in Watts over tank Wall 3 without shunts.

## STRAY LOSSES APPLYING POYNTING'S VECTOR

For calculating stray losses due to the zero-sequence flux in conducting steel plates, on the surface of which the field is incident having a peak value of  $H_{ms}$ , authors applied the Turowski's equation [7] using semi-empirical correction factors for nonlinearities. Turowski's equation is defined in (7) and obtained from the numerical integration of the analytically expressed Poynting's theorem [8], where  $x$  and  $y$  are the cartesian coordinates of each point.

$$P_s(x, y) = a_p \iint_s \sqrt{\frac{\omega \mu}{2\sigma}} \frac{|H_{ms}(x, y)|^{2x_p}}{2} dx dy \quad (7)$$

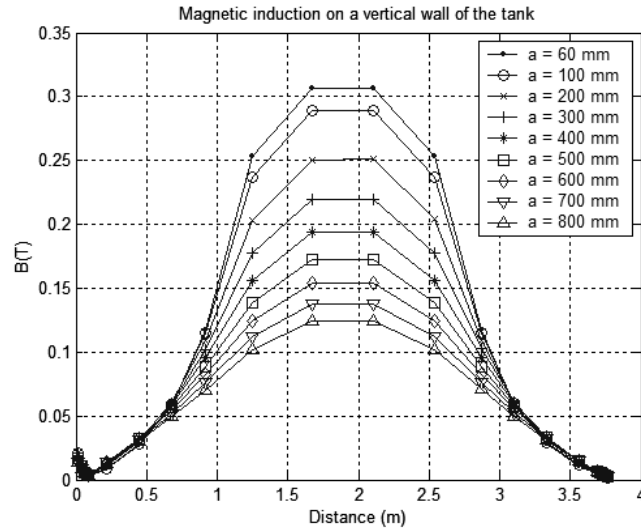
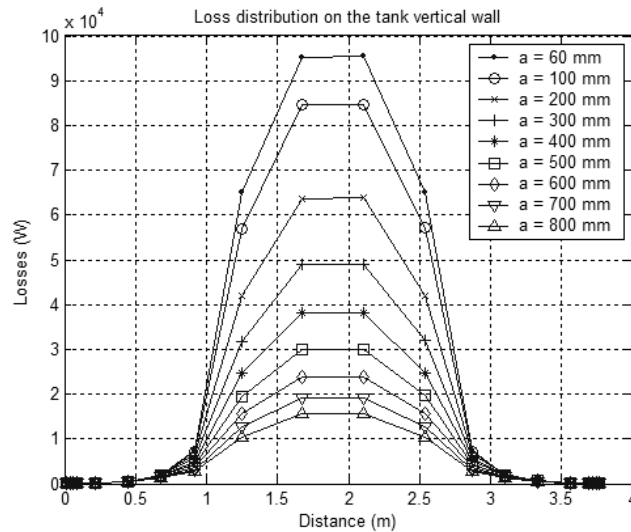
Where  $\omega$  is the angular frequency,  $\sigma$  is the conductivity and  $\mu$  is the magnetic permeability of the material. By means of (4) the stray losses per unit surface area ( $\text{W}/\text{m}^2$ ) are integrated on the entire plate area  $s$ . The factor  $a_p$  is the linearization coefficient, and takes into account variations in the value of the relative permeability inside the material. For non-magnetic plates  $a_p=1$ . A semi-empirical correction factor of  $x_p=1$  is used for non-magnetic metals, and  $x_p=1.05$  to 1.14 for magnetic steel depending upon the structure of the investigated element, the nature of the field and the type of the steel.

#### IV. APPLICATION AND RESULTS

In order to check the RNM2D\_0 tool, a fictitious 100 MVA(Y-Yn) transformer of 220kV / 30 kV was considered. It has star-connected winding without any triangle tertiary winding. Also, shunts were not considered in the simulation, therefore the zero-sequence flux will be closed though the cover and tank wall. Under these conditions a line-to-ground fault at the secondary side was induced, where the zero sequence current reaches a 2.3 per unit value related to the rated current.

In Fig. 6 the magnetic induction  $B$  in Tesla over Wall 3 without shunts is shown, being  $a$  the distance from the HV winding to the tank wall. It can be seen how the magnetic induction significantly reduces its maximum value as the distance to the winding increases. In Fig. 7 stray losses due to the zero-sequence flux are plotted over tank Wall 3, decreasing as the distance  $a$  from the HV winding to the tank wall increases.

Eddy currents losses are responsible for the tank heating effect and proportional to the magnitude of the zero-sequence flux inducing them. Therefore, as already mentioned, prolonged operation of a transformer with significant zero-sequence flux can result in potentially harmful heating of metallic structural parts external to the core.

#### V. CONCLUSIONS

This paper presents a rapid and easy-to-use tool RNM2D\_0 with negligible computing times, to calculate the magnetic values under unbalanced conditions, without the presence of compensatory tertiary winding and shunts. The tool, based on the Reluctance Network Method, allows computing the additional losses due to the presence of zero-sequence flux in a three-phase and three limb core type transformers.

From results of the evaluated case, it can be noted that the values of additional losses generated on the tank wall are of great magnitude. As power losses are responsible for the heating effect, prolonged operation of a transformer with significant zero-sequence flux can result in excessive heating of metallic structural parts external to the core.

#### REFERENCES

- [1] Marina A. Tsili and Stavros A. Papathanassiou, *Zero-Sequence Flux Protection of a Three-limb Core Power Transformer*.
- [2] J. Turowski, "Fast Computation of Coupled Fields in Complex, 3-D, Industrial Electromagnetic Structures", The International Journal for Computation and Mathematics in Electrical and Electronic Engineering (COMPEL), Vol. 17 No. 4, 1998, pp. 489-505
- [3] J. Turowski, M. Turowski, and M. Kopec, "Method of ThreeDdimensional Network Solution of Leakage Field of Three-Phase Transformers," IEEE Transactions on Magnetics, vol. 26, no. 5, Sept. 1990, pp. 2911-2919
- [4] Xose M. Lopez-Fernandez, J. Turowski, D. Souto Revenga, A. Soto Rodriguez, *Upgrading of Large Transformers 3D-Design: Energy-Saving and Reliability of Electric Power System*, Proc. 2<sup>nd</sup> International Conference on Electrical Engineering (CEE07), Coimbra-Portugal, 26-28 November 2007, pp. 580-585.
- [5] J. Turowski, "Stray Losses, Screening, and Local Excessive Heating Hazard in Large Power Transformers". Chapter in CD book *Transformers in Practice*, Vigo 2006. Publisher and editor Xose M. Lopez-Fernandez, co-Editors: J. Turowski and M. Kazmierski, E. Lesniewska and B. Ertan.
- [6] J. Turowski: "Reluctance Networks". Chapter 4, pp.145-178 and "Coupled Fields". Chapter 6, pp. 234 - 284. in book *Computational Magnetism*. Ed. Chapman & Hall. London 1990, editor J.Sykulski (*Extended translation from Polish: J.Turowski (coauthor and edit.) et al. "Ossolineum", Wroclaw, 1990*)
- [7] J. Turowski and A. Pelikant, *Eddy Currents Losses and Hot-Spot Evaluation in Cover Plates of Power Transformers*, IEE Proc. Electr. Power Appl., vol. 144, pp. 435–440, Nov. 1997.
- [8] Pelikant and J. Turowski, *Field and Power Loss Distribution on Covers of Power Transformers*, COMPEL, vol.17, no. 1/2/3, pp. 307-312, 1998.
- [9] J. Turowski: "Elektrodynamika Techniczna" (in Polish) Warszawa, WNT 1993